

STROKE	A	B
1" [25.4]	2.875 [73.0]	5.553 [141.0]
2" [50.8]	3.875 [98.4]	7.553 [191.8]
3" [76.2]	4.875 [123.8]	9.553 [242.6]

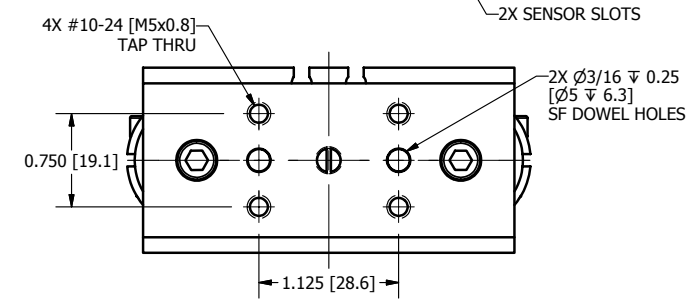
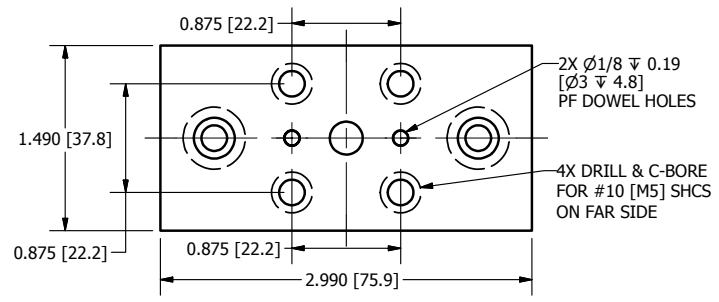
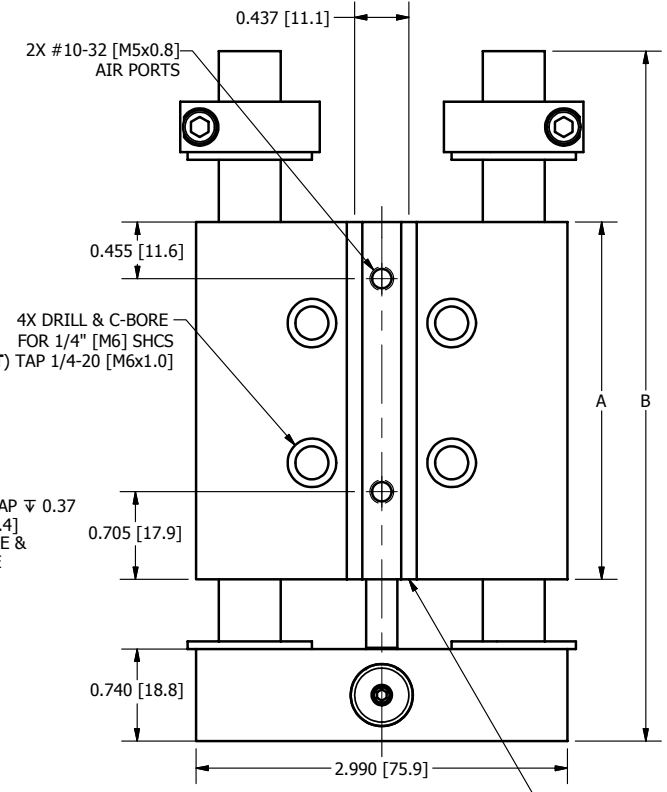
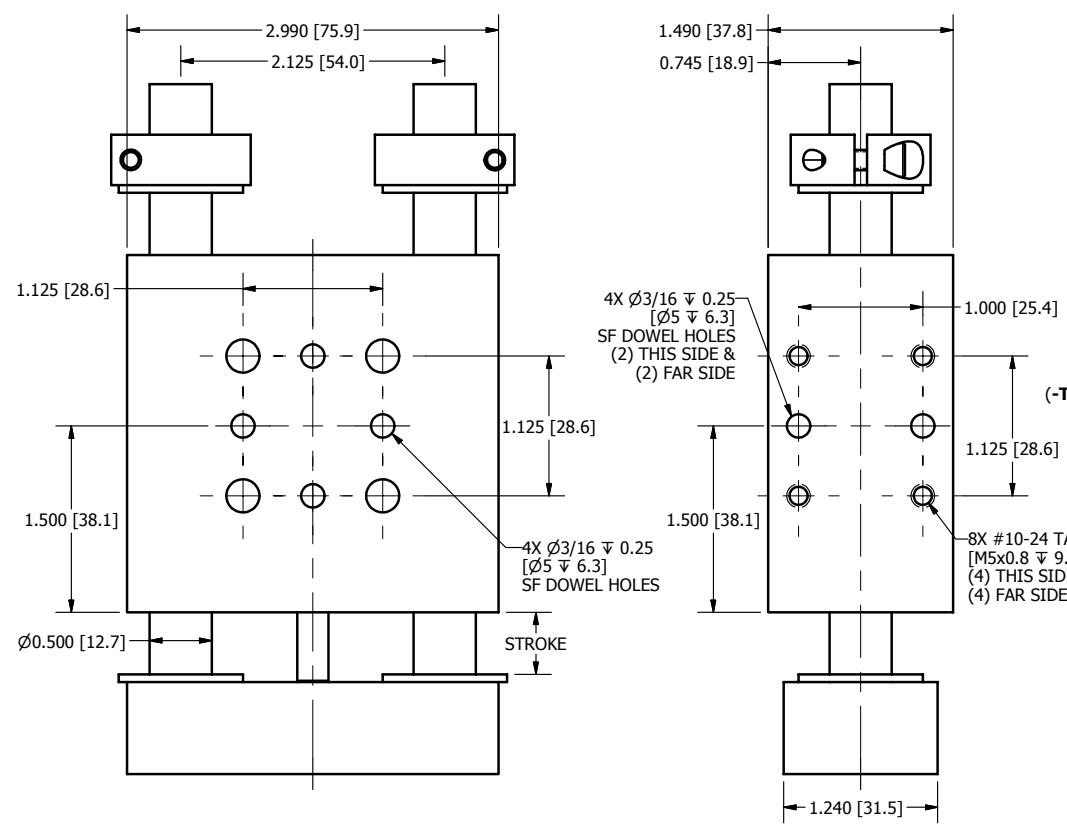

OPTIONAL (-B) END PLATE FOR CONNECTION TO LT-2