

| STROKE    | A            | B             |
|-----------|--------------|---------------|
| 1" [25.4] | 2.375 [60.3] | 4.575 [90.8]  |
| 2" [50.8] | 3.375 [85.7] | 6.575 [167.0] |

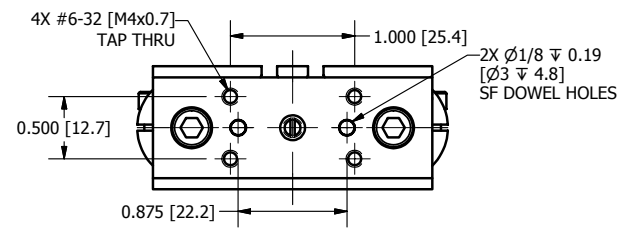
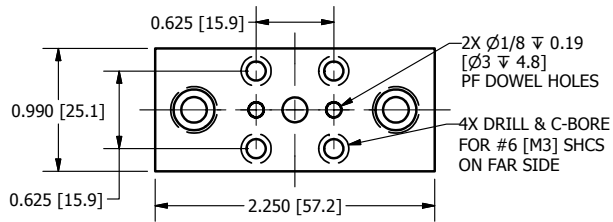
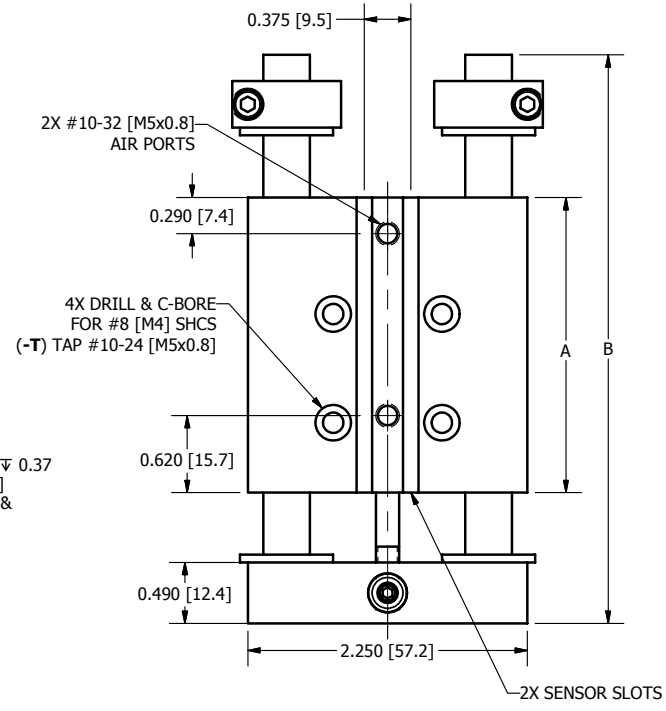
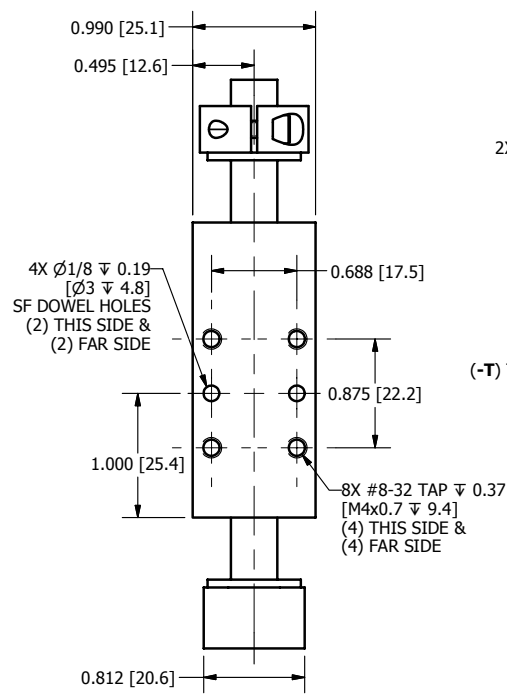
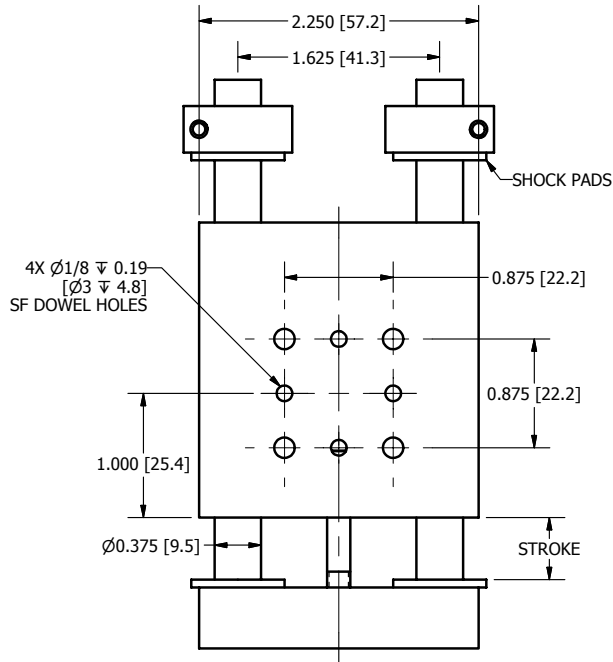

OPTIONAL (-B) END PLATE FOR CONNECTION TO LT-1